

ER -2, 3 or 4 caused by data connection issues SV Mini - Tech Note

WARNING NOTE: RISK OF ELECTRIC SHOCK

Isolate and turn mains power OFF to spa before touching any equipment

1. Please ensure the mains power is isolated and turned off.

Undo the four screws as shown (fig 1) and remove the front cover from the SV Mini controller.

2. Disconnect the heater sensor cable from the controller. The sensor is in the far right RJ45 socket marked "Heater" (fig 2)

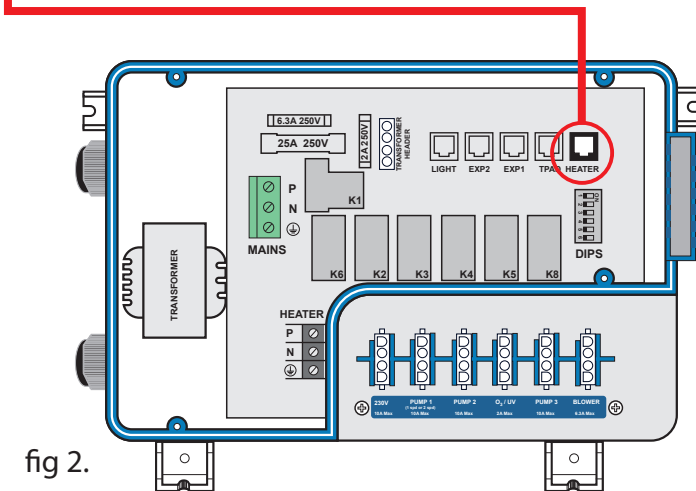

fig 2.

3. Inspect Plug (fig 3) and ensure the 8 brass contacts are free from any debris such as glue or oxidisation.

4. Reconnect the Heater sensor into the heater socket. Ensure sensor cable is routed downwards and goes to the bottom groove (fig 4)

5. Place the outer cover back on the SV Mini controller and reset the power to the spa.

6. Carry out Eeprom reset

SV Mini controllers feature a hidden OEM configuration menu which allows customisation of certain important spa control settings.

- To access the OEM config menu on a SV Mini 1 press and hold the hidden buttons (shown by the red dotted circles aside Fig 5)

- Use the DOWN buttons to navigate through the configuration menu items to EPRM

- When EPRM is displayed on screen press the OK button to execute the software reset

- The display will very briefly flash ESET as the reset process takes place.

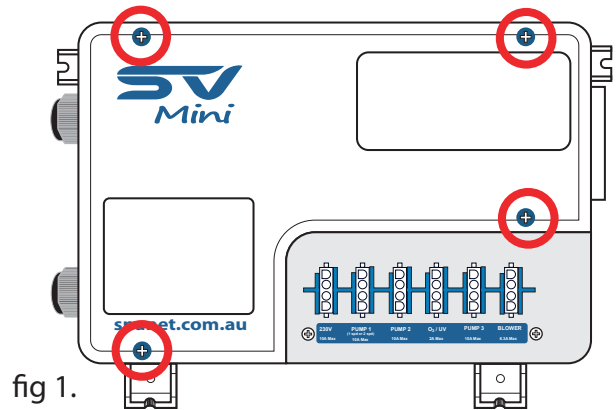

fig 1.



fig 3.

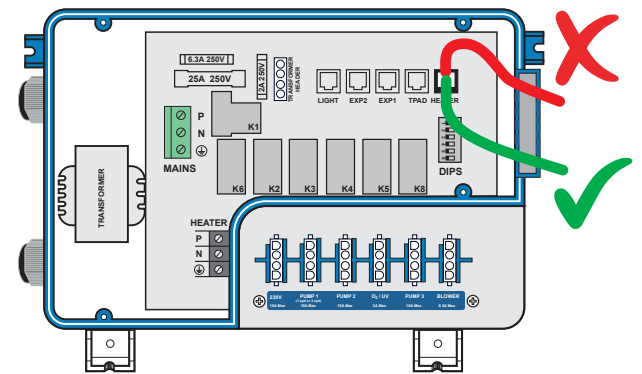

fig 4.

SV Mini 1



fig 5.